

DATASHEET

NI 9242 Datasheet

3 AI/1 Neutral, 250 Vrms L-N/400 Vrms L-L, 24 Bit, 50 kS/s/ch
Simultaneous



- Screw-terminal connectivity for up to 12 AWG cables
- Protective backshell
- 250 Vrms, CAT III, channel-to-earth working voltage

The NI 9242 is a C series analog input module that offers three channels for measurements between the signal and the neutral channel, and the neutral channel provides measurements between the neutral terminal and the chassis ground. With this configuration, you can connect single- or three-phase measurement configurations such as WYE and delta. If you are developing power monitoring, metering, or quality analysis applications, consider the NI LabVIEW Electrical Power Suite, which is compatible with both NI CompactRIO and CompactDAQ systems.



Kit Contents

- NI 9242
- NI 9242 Getting Started Guide
- NI 9968 4-Position Screw-Terminal Connector
- NI 9967 Strain Relief and Operator Protection

C SERIES HIGH VOLTAGE ANALOG INPUT MODULE COMPARISON							
Product Name	Signal Levels	Channels	Sample Rate	Simultaneous	Input Noise	Connectivity	Isolation/Safety Voltages
NI 9221	± 60 V	8	800 kS/s	No	0.7 LSB RMS	DSUB Screw-Terminal Spring-Terminal	Ch-Earth ground 250 Vrms, CAT II (Screw/Spring Terminal) ± 60 VDC, CAT I (DSUB)
NI 9225	300 Vrms	3	50 kS/s/ch	Yes	2 mVrms	Screw-Terminal	Ch-Ch 600 Vrms, CAT II
NI 9229	± 60 V	4	50 kS/s/ch	Yes	320 µVrms	Screw-Terminal BNC	Ch-Earth ground 250 Vrms, CAT II (Screw-Terminal) ±60 VDC, CAT I (BNC)
NI 9242	250 Vrms L-N 400 Vrms L-L	3 AI 1 Neutral	50 kS/s/ch	Yes	3 mVrms	Screw-Terminal	Ch-Earth ground 250 Vrms, CAT III
NI 9244	400 Vrms L-N 690 Vrms L-L	3 AI 1 Neutral	50 kS/s/ch	Yes	6 mVrms	Screw-Terminal	Ch-Earth ground 400 Vrms, CAT II, or 300 Vrms CAT III at 5,000 m altitude

NI C Series Overview



NI provides more than 100 C Series modules for measurement, control, and communication applications. C Series modules can connect to any sensor or bus and allow for high-accuracy measurements that meet the demands of advanced data acquisition and control applications.

- Measurement-specific signal conditioning that connects to an array of sensors and signals
- Isolation options such as bank-to-bank, channel-to-channel, and channel-to-earth ground
- -40 °C to 70 °C temperature range to meet a variety of application and environmental needs
- Hot-swappable

The majority of C Series modules are supported in both CompactRIO and CompactDAQ platforms and you can move modules from one platform to the other with no modification.

CompactRIO



CompactRIO combines an open-embedded architecture with small size, extreme ruggedness, and C Series modules in a platform powered by the NI LabVIEW reconfigurable I/O (RIO) architecture. Each system contains an FPGA for custom timing, triggering, and processing with a wide array of available modular I/O to meet any embedded application requirement.

CompactDAQ

CompactDAQ is a portable, rugged data acquisition platform that integrates connectivity, data acquisition, and signal conditioning into modular I/O for directly interfacing to any sensor or signal. Using CompactDAQ with LabVIEW, you can easily customize how you acquire, analyze, visualize, and manage your measurement data.



Software

LabVIEW Professional Development System for Windows



- Use advanced software tools for large project development
- Generate code automatically using DAQ Assistant and Instrument I/O Assistant
- Use advanced measurement analysis and digital signal processing
- Take advantage of open connectivity with DLLs, ActiveX, and .NET objects
- Build DLLs, executables, and MSI installers

NI LabVIEW FPGA Module



- Design FPGA applications for NI RIO hardware
- Program with the same graphical environment used for desktop and real-time applications
- Execute control algorithms with loop rates up to 300 MHz
- Implement custom timing and triggering logic, digital protocols, and DSP algorithms
- Incorporate existing HDL code and third-party IP including Xilinx IP generator functions
- Purchase as part of the LabVIEW Embedded Control and Monitoring Suite

NI LabVIEW Real-Time Module

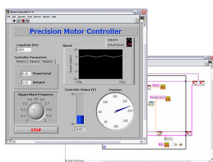

- Design deterministic real-time applications with LabVIEW graphical programming
- Download to dedicated NI or third-party hardware for reliable execution and a wide selection of I/O
- Take advantage of built-in PID control, signal processing, and analysis functions
- Automatically take advantage of multicore CPUs or set processor affinity manually
- Take advantage of real-time OS, development and debugging support, and board support
- Purchase individually or as part of a LabVIEW suite

Input Circuitry

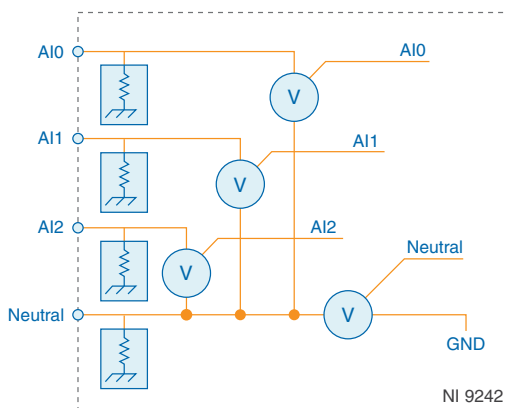

- Each channel on the NI 9242 provides an independent signal path and ADC. Each terminal has the same input impedance to ground.
- The NI 9242 returns the voltage between each AI terminal and the Neutral terminal as well as the voltage between the Neutral terminal and the chassis ground.

Filtering

The NI 9242 uses a combination of analog and digital filtering to provide an accurate representation of in-band signals and reject out-of-band signals. The filters discriminate between signals based on the frequency range, or bandwidth, of the signal. The three important bandwidths to consider are the passband, the stopband, and the anti-imaging bandwidth.

The NI 9242 represents signals within the passband, as quantified primarily by passband ripple and phase nonlinearity. All signals that appear in the alias-free bandwidth are either unaliased signals or signals that have been filtered by at least the amount of the stopband rejection.

Passband

The signals within the passband have frequency-dependent gain or attenuation. The small amount of variation in gain with respect to frequency is called the passband flatness. The digital filters of the NI 9242 adjust the frequency range of the passband to match the data rate. Therefore, the amount of gain or attenuation at a given frequency depends on the data rate.

Figure 1. Typical Passband Response for the NI 9242

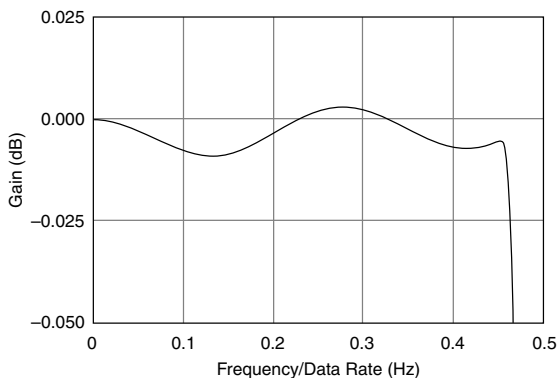

Stopband

The filter significantly attenuates all signals above the stopband frequency. The primary goal of the filter is to prevent aliasing. Therefore, the stopband frequency scales precisely with the data rate. The stopband rejection is the minimum amount of attenuation applied by the filter to all signals with frequencies within the stopband.

Alias-Free Bandwidth

Any signals that appear in the alias-free bandwidth are not aliased artifacts of signals at a higher frequency. The alias-free bandwidth is defined by the ability of the filter to reject frequencies above the stopband frequency. The alias-free bandwidth is equal to the data rate minus the stopband frequency.

Data Rates

The frequency of a master timebase (f_M) controls the data rate (f_S) of the NI 9242. The NI 9242 includes an internal master timebase with a frequency of 12.8 MHz, but the module also can accept an external master timebase or export its own master timebase. To synchronize the data rate of an NI 9242 with other modules that use master timebases to control sampling, all of the modules must share a single master timebase source.

The following equation provides the available data rates of the NI 9242:

$$f_s = \frac{f_M \div 256}{n}$$

where n is any integer from 1 to 31.

However, the data rate must remain within the appropriate data rate range. When using the internal master timebase of 12.8 MHz, the result is data rates of 50 kS/s, 25 kS/s, 16.667 kS/s, and so on down to 1.613 kS/s depending on the value of n . When using an external timebase with a frequency other than 12.8 MHz, the NI 9242 has a different set of data rates.



Note The NI 9151 R Series Expansion chassis does not support sharing timebases between modules.

NI 9242 Specifications

The following specifications are typical for the range -40 °C to 70 °C unless otherwise noted.



Caution Do not operate the NI 9242 in a manner not specified in this document. Product misuse can result in a hazard. You can compromise the safety protection built into the product if the product is damaged in any way. If the product is damaged, return it to NI for repair.

Input Characteristics

Scaling coefficient	59,605 nV/LSB
Number of channels	4 analog input channels
ADC resolution	24 bits
Type of ADC	Delta-Sigma (with analog prefiltering)
Sampling mode	Simultaneous
Internal master timebase (f_M)	
Frequency	12.8 MHz
Accuracy	±100 ppm maximum
Data rate range (f_s) using internal master timebase	
Minimum	1.613 kS/s
Maximum	50 kS/s
Data rate range (f_s) using external master timebase	
Minimum	390.625 S/s
Maximum	51.2 kS/s

Data rates (f_s)¹

$$\frac{f_M \div 256}{n}, n = 1, 2, \dots, 31$$

Input voltage range (AIx-to-Ground, Neutral-to-Ground, AIx-to-Neutral)

Typical	500 Vpk
Minimum	497 Vpk
Overvoltage withstand	500 Vrms continuous, 600 Vrms for 10 s
Surge withstand	8 kV (1.2 μ s/50 μ s)
Input coupling	DC
Input impedance, AIx-to-Ground and Neutral-to-Ground	1 M Ω

Table 1. DC and AC Accuracy

Measurement Conditions		Percent of Reading (Gain Error)	Percent of Range (Offset Error) ²
Calibrated	Maximum, (-40 °C to 70 °C)	0.26%	0.14%
	Typical, (23 °C \pm 5 °C)	0.05%	0.022%



Note Accuracy specifications are valid for L-L, L-N and L-Earth measurements.

Input noise at 50 kS/s³

N-Earth and L-Earth	2.12 mVrms
L-N and L-L	3 mVrms



Note When measuring the amplitude of the fundamental frequency over one or several power cycles, the noise of the measurement reduces significantly (theoretically with the square root of the number of samples in the acquisition window).

Nonlinearity (at 25 °C) 20 ppm

Stability

Gain drift	12.1 ppm/°C
Offset drift	3.4 mV/°C

¹ The data rate must remain within the appropriate data rate range.

² Range equals 354 V (250 Vrms \times $\sqrt{2}$).

³ The module returns L-N and N-Earth values only.

Post calibration gain match (channel-to-channel, maximum)

Up to 20 kHz	95 mdB
Up to 10 kHz	44 mdB
Up to 3.8 kHz	30 mdB

Phase mismatch (channel-to-channel) 0.138°/ kHz maximum

Phase mismatch (module-to-module, maximum) $0.138^\circ/\text{kHz} + 360^\circ * f_{in}/f_M$

Phase nonlinearity ($f_s = 50$ kS/s)

0 kHz to 10 kHz	0.017° maximum
0 kHz to 20 kHz	0.034° maximum

Input delay $40 \frac{5}{512}/f_s + 1.5 \mu\text{s}$

Passband Frequency $0.453 * f_s$

Flatness

0 kHz to 20 kHz	±50 mdB maximum
0 kHz to 10 kHz	±20 mdB maximum

Negative phase sequence error at 50 Hz and 60 Hz

At 5% unbalance	
Maximum	0.21%
Typical	0.09%
At 1% unbalance	
Maximum	0.22%
Typical	0.1%

Zero phase sequence error at 50 Hz and 60 Hz

At 5% unbalance	
Maximum	0.21%
Typical	0.09%
At 1% unbalance	
Maximum	0.22%
Typical	0.1%

Stopband

Frequency	$0.547 * f_s$
Rejection	-95 dB

Alias-free bandwidth $0.453 * f_s$

Anti-alias rejection ($f_s = 50$ kS/s)	53 dB
-3 dB bandwidth ($f_s = 50$ kS/s)	$0.49 * f_s$
Crosstalk	
60 Hz	-105 dB
1 kHz	-79 dB
CMRR ($f_{in} = 60$ Hz)	-75 dB
SFDR (1 kHz, -60 dBFS)	-120 dB
Total Harmonic Distortion (THD), up to 1 kHz	-100 dB

Power Requirements

Power consumption from chassis	
Active mode	332 mW maximum
Sleep mode	50 μ W maximum
Thermal dissipation	
Active mode	582 mW maximum
Sleep mode	250 mW maximum

Physical Characteristics

If you need to clean the module, wipe it with a dry towel.



Tip For two-dimensional drawings and three-dimensional models of the C Series module and connectors, visit ni.com/dimensions and search by module number.

Screw-terminal wiring	
Gauge	0.2 mm ² to 3.0 mm ² (24 AWG to 12 AWG) copper conductor wire
Wire strip length	7 mm (0.28 in.) of insulation stripped from the end
Temperature rating	90 °C minimum
Torque for screw terminals	0.5 N · m to 0.6 N · m (4.4 lb · in. to 5.3 lb · in.)
Wires per screw terminal	One wire per screw terminal
Ferrules	0.25 mm ² to 2.5 mm ²

Connector securement

Securement type	Screw flanges provided
Torque for screw flanges	0.5 N · m (4.42 lb · in.)
Weight	150 g (5.3 oz)

Safety Voltages

Connect only voltages that are within the following limits.

Maximum working voltage, channel-to earth ground

Continuous	250 Vrms, Measurement Category III
------------	------------------------------------

Division 2 and Zone 2 hazardous locations applications

Channel-to-earth ground	250 Vrms, Measurement Category III
-------------------------	------------------------------------

Measurement Category III is for measurements performed in the building installation at the distribution level. This category refers to measurements on hard-wired hardware such as hardware in fixed installations, distribution boards, and circuit breakers. Other examples are wiring, including cables, bus bars, junction boxes, switches, socket outlets in the fixed installation, and stationary motors with permanent connections to fixed installations.



Caution Do not connect the NI 9242 to signals or use for measurements within Measurement Category IV.

Hazardous Locations

U.S. (UL)	Class I, Division 2, Groups A, B, C, D, T4; Class I, Zone 2, AEx nA IIC T4
Canada (C-UL)	Class I, Division 2, Groups A, B, C, D, T4; Class I, Zone 2, Ex nA IIC T4
Europe (ATEX) and International (IECEx)	Ex nA IIC T4 Gc

Safety and Hazardous Locations Standards

This product is designed to meet the requirements of the following electrical equipment safety standards for measurement, control, and laboratory use:

- IEC 61010-1, EN 61010-1
- UL 61010-1, CSA 61010-1
- EN 60079-0:2012, EN 60079-15:2010
- IEC 60079-0: Ed 6, IEC 60079-15; Ed 4
- UL 60079-0; Ed 5, UL 60079-15; Ed 3
- CSA 60079-0:2011, CSA 60079-15:2012



Note For UL and other safety certifications, refer to the product label or the [Online Product Certification](#) section.

Electromagnetic Compatibility

This product meets the requirements of the following EMC standards for electrical equipment for measurement, control, and laboratory use:

- EN 61326-1 (IEC 61326-1): Class A emissions; Industrial immunity
- EN 55011 (CISPR 11): Group 1, Class A emissions
- EN 55022 (CISPR 22): Class A emissions
- EN 55024 (CISPR 24): Immunity
- AS/NZS CISPR 11: Group 1, Class A emissions
- AS/NZS CISPR 22: Class A emissions
- FCC 47 CFR Part 15B: Class A emissions
- ICES-001: Class A emissions



Note In the United States (per FCC 47 CFR), Class A equipment is intended for use in commercial, light-industrial, and heavy-industrial locations. In Europe, Canada, Australia and New Zealand (per CISPR 11) Class A equipment is intended for use only in heavy-industrial locations.



Note Group 1 equipment (per CISPR 11) is any industrial, scientific, or medical equipment that does not intentionally generate radio frequency energy for the treatment of material or inspection/analysis purposes.



Note For EMC declarations and certifications, and additional information, refer to the [Online Product Certification](#) section.

CE Compliance

This product meets the essential requirements of applicable European Directives, as follows:

- 2014/35/EU; Low-Voltage Directive (safety)
- 2014/30/EU; Electromagnetic Compatibility Directive (EMC)
- 94/9/EC; Potentially Explosive Atmospheres (ATEX)

Online Product Certification

Refer to the product Declaration of Conformity (DoC) for additional regulatory compliance information. To obtain product certifications and the DoC for this product, visit ni.com/certification, search by model number or product line, and click the appropriate link in the Certification column.

Shock and Vibration

To meet these specifications, you must panel mount the system.

Operating vibration

Random (IEC 60068-2-64)	5 g _{rms} , 10 Hz to 500 Hz
Sinusoidal (IEC 60068-2-6)	5 g, 10 Hz to 500 Hz
Operating shock (IEC 60068-2-27)	30 g, 11 ms half sine; 50 g, 3 ms half sine; 18 shocks at 6 orientations

Environmental

Refer to the manual for the chassis you are using for more information about meeting these specifications.

Operating temperature (IEC 60068-2-1, IEC 60068-2-2)	-40 °C to 70 °C
Storage temperature (IEC 60068-2-1, IEC 60068-2-2)	-40 °C to 85 °C
Ingress protection	IP40
Operating humidity (IEC 60068-2-78)	10% RH to 90% RH, noncondensing
Storage humidity (IEC 60068-2-78)	5% RH to 95% RH, noncondensing
Pollution Degree	2
Maximum altitude	5,000 m

Indoor use only.

Environmental Management

NI is committed to designing and manufacturing products in an environmentally responsible manner. NI recognizes that eliminating certain hazardous substances from our products is beneficial to the environment and to NI customers.

For additional environmental information, refer to the *Minimize Our Environmental Impact* web page at ni.com/environment. This page contains the environmental regulations and directives with which NI complies, as well as other environmental information not included in this document.

Waste Electrical and Electronic Equipment (WEEE)



EU Customers At the end of the product life cycle, all NI products must be disposed of according to local laws and regulations. For more information about how to recycle NI products in your region, visit ni.com/environment/weee.

电子信息产品污染控制管理办法（中国 RoHS）

  **中国客户** National Instruments 符合中国电子信息产品中限制使用某些有害物质指令 (RoHS)。关于 National Instruments 中国 RoHS 合规性信息，请登录 ni.com/environment/rohs_china。(For information about China RoHS compliance, go to ni.com/environment/rohs_china.)

Calibration

You can obtain the calibration certificate and information about calibration services for the NI 9242 at ni.com/calibration.

Calibration interval	1 year
----------------------	--------

Refer to the *NI Trademarks and Logo Guidelines* at ni.com/trademarks for information on NI trademarks. Other product and company names mentioned herein are trademarks or trade names of their respective companies. For patents covering NI products/technology, refer to the appropriate location: **Help»Patents** in your software, the `patents.txt` file on your media, or the *National Instruments Patent Notice* at ni.com/patents. You can find information about end-user license agreements (EULAs) and third-party legal notices in the readme file for your NI product. Refer to the *Export Compliance Information* at ni.com/legal/export-compliance for the NI global trade compliance policy and how to obtain relevant HTS codes, ECCNs, and other import/export data. NI MAKES NO EXPRESS OR IMPLIED WARRANTIES AS TO THE ACCURACY OF THE INFORMATION CONTAINED HEREIN AND SHALL NOT BE LIABLE FOR ANY ERRORS. U.S. Government Customers: The data contained in this manual was developed at private expense and is subject to the applicable limited rights and restricted data rights as set forth in FAR 52.227-14, DFAR 252.227-7014, and DFAR 252.227-7015.

© 2016 National Instruments. All rights reserved.